

Avion			
Fig	Aresti	K	
1	8.6.2.1 9.1.1.1 9.4.3.2	12 6 5	23
2	8.5.2.2 9.1.2.2	14 6	20
3	8.4.4.2 9.1.1.1	14 6	20
4	5.2.1.1 9.8.1.1 9.1.5.2	17 7 4	28
5	7.4.1.1 9.9.3.4	10 11	21
6	7.2.2.1 9.4.3.2	6 5	11
7	1.1.1.1 9.9.3.4	2 11	13
8	8.5.5.1 9.2.3.4	10 9	19
9	8.4.2.2	17	17
10	7.2.2.1 9.1.3.3 9.1.3.5	6 6 9	21
11	2.3.4.1	15	15
Total K = 208 (max K = 210)			
Le K Aresti normal de la figure 11 a été changé selon le règlement 2024 france national_2 inconnu			

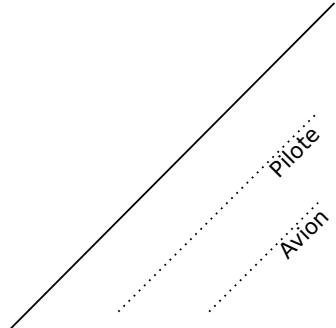

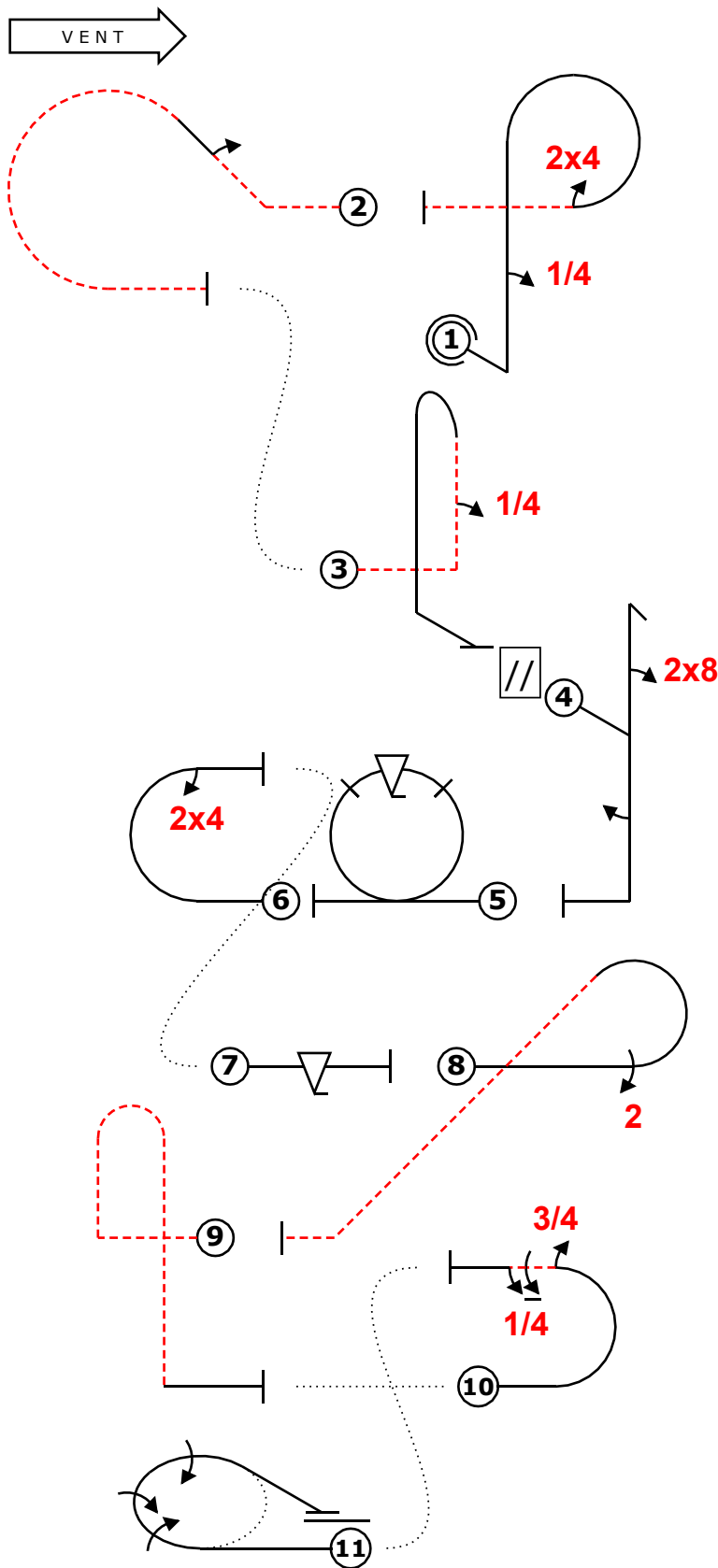

Avion			
Fig	Aresti	K	
1	8.6.2.1	12	23
	9.1.1.1	6	
	9.4.3.2	5	
2	8.5.2.2	14	20
	9.1.2.2	6	
3	8.4.4.2	14	20
	9.1.1.1	6	
4	5.2.1.1	17	28
	9.8.1.1	7	
	9.1.5.2	4	
5	7.4.1.1	10	21
	9.9.3.4	11	
6	7.2.2.1	6	11
	9.4.3.2	5	
7	1.1.1.1	2	13
	9.9.3.4	11	
8	8.5.5.1	10	19
	9.2.3.4	9	
9	8.4.2.2	17	17
10	7.2.2.1	6	21
	9.1.3.3	6	
	9.1.3.5	9	
11	2.3.4.1	15	15
Total K = 208 (max K = 210)			
Le K Aresti normal de la figure 11 a été changé selon le règlement 2024 france national_2 inconnu			

